

Řetězová kola přesná s kalenými zuby Finished sprockets with hardened teeth

Řetězové kolo přesné s indukčně kalenými zuby pro válečkový řetěz dle DIN 8187 ISO/R606
Finished sprocket with hardened teeth for roller chain to DIN 8187 ISO/R606

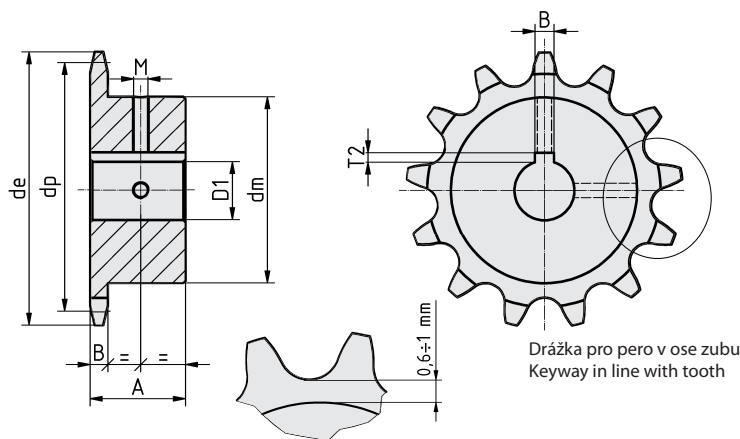

10B-1



Indukčně kalené zuby HRC 45+53
Induction hardened teeth HRC 45+53

Řetěz • Chain		
Rozteč • Pitch	P	9,525 mm
Vnitřní šířka • Inner width	b _i	5,72 mm
Průměr válečku • Roller diameter	D	6,35 mm
Řetězové kolo • Sprocket		
Šířka zubů • Sprocket tooth width	B _i	9,1 mm
Materiál • Raw material	ocel • steel C40/C45 kalena / hardened	

Počet zubů Teeth number Z	d _e [mm]	d _p [mm]	d _m [mm]	A [mm]	D ₁ [mm]	Hmotnost Weight [kg]	Počet zubů Teeth number Z	d _e [mm]	d _p [mm]	d _m [mm]	A [mm]	D ₁ [mm]	Hmotnost Weight [kg]	Počet zubů Teeth number Z	d _e [mm]	d _p [mm]	d _m [mm]	A [mm]	D ₁ [mm]	Hmotnost Weight [kg]
13	73,2	66,32	47	30	16	0,49	18	98,3	91,42	70	30	20	1,03	23	123,4	116,58	80	30	20	1,49
					19	0,46						22	1,02						22	1,47
					20	0,45						24	1,00						24	1,45
					22	0,43						25	0,99						25	1,43
					24	0,41						28	0,96						28	1,41
					25	0,40						30	0,94						30	1,39
					28	0,37						32	0,92						32	1,37
					30	0,35						35	0,90						35	1,34
												38	0,88						38	1,31
												40	0,86						40	1,29
14	78,2	71,34	52	30	16	0,60	19	103,3	96,45	70	30	20	1,08	24	128,5	121,62	80	30	20	1,54
					19	0,57						22	1,06						22	1,52
					20	0,56						24	1,04						24	1,50
					22	0,54						25	1,03						25	1,49
					24	0,52						28	1,00						28	1,47
					25	0,51						30	0,98						30	1,45
					28	0,48						32	0,96						32	1,43
					30	0,46						35	0,93						35	1,41
												40	0,88						40	1,36
15	83,2	76,36	57	30	19	0,69	20	108,4	101,49	75	30	20	1,23	25	133,5	126,66	80	30	22	1,59
					20	0,68						22	1,21						24	1,57
					22	0,66						24	1,19						25	1,56
					25	0,63						25	1,18						28	1,53
					28	0,61						28	1,15						30	1,51
					30	0,59						30	1,13						32	1,49
					32	0,57						32	1,11						35	1,46
					35	0,54						35	1,09						38	1,43
16	88	81,37	60	30	20	0,77	21	113,4	106,52	75	30	20	1,27	25				25	1,56	
					22	0,75						22	1,25						28	1,53
					24	0,73						24	1,23						30	1,51
					25	0,72						25	1,22						32	1,49
					28	0,69						28	1,20						35	1,46
					30	0,67						30	1,18						38	1,43
					32	0,65						32	1,16						40	1,41
					35	0,62						35	1,13						42	1,39
17	93,2	86,39	60	30	20	0,81						22	1,25							
					22	0,79						24	1,23							
					24	0,77						25	1,22							
					25	0,76						28	1,20							
					28	0,73						30	1,18							
					30	0,71						32	1,16							
					32	0,69						35	1,13							
					35	0,66						38	1,10							
												40	1,08							

- Rozměry drážky pro pero (B, T2) a stavěcích šroubů (M) jsou uvedeny na straně 33.
- Řetězová kola mají indukčně kalené zuby, zhotovený otvor včetně drážky pro pero a dva otvory pro stavěcí šrouby v poloze nad drážkou pro pero a pod úhlem 90°, což umožňuje rychlou montáž bez nutnosti dalšího opracování.
- Mimo standardní rozměry upravíme/vyrobíme polotovary v naší obrobně dle Vašich požadavků.
- Keyway dimensions (B, T2) and setscrews dimensions (M) are stated on page 33.
- Sprockets are with induction hardened teeth, finished bore including keyway and 2 setscrew holes in position above keyway and under 90° angle. This sprocket version enables sprocket assembly without any other finishing.
- Upon request we adapt/produce sprockets/plate wheels out of standard dimensions in our workshop.