

## Řetězová kola přesná s kalenými zuby Finished sprockets with hardened teeth

Řetězové kolo přesné s indukčně kalenými zuby pro válečkový řetěz dle DIN 8187 ISO/R606  
Finished sprocket with hardened teeth for roller chain to DIN 8187 ISO/R606

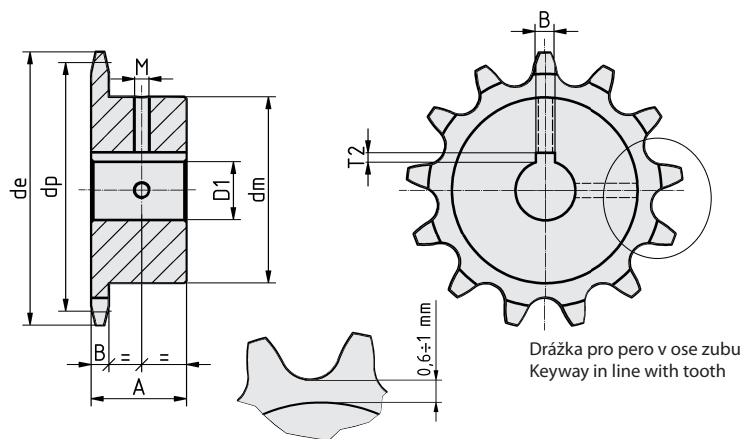

12B-1



Drážka pro pero v ose zuby  
Keyway in line with tooth

Indukčně kalené zuby HRC 45+53  
Induction hardened teeth HRC 45+53

Řetěz • Chain		
Rozteč • Pitch	P	19,05 mm
Vnitřní šířka • Inner width	b <sub>i</sub>	11,68 mm
Průměr válečku • Roller diameter	D	12,07 mm
Řetězové kolo • Sprocket		
Šířka zubů • Sprocket tooth width	B <sub>i</sub>	11,1 mm
Materiál • Raw material	ocel • steel C40/C45 kalena / hardened	

Počet zubů Teeth number Z	d <sub>e</sub> [mm]	d <sub>p</sub> [mm]	d <sub>m</sub> [mm]	A [mm]	D <sub>1</sub> [mm]	Hmotnost Weight [kg]	Počet zubů Teeth number Z	d <sub>e</sub> [mm]	d <sub>p</sub> [mm]	d <sub>m</sub> [mm]	A [mm]	D <sub>1</sub> [mm]	Hmotnost Weight [kg]	Počet zubů Teeth number Z	d <sub>e</sub> [mm]	d <sub>p</sub> [mm]	d <sub>m</sub> [mm]	A [mm]	D <sub>1</sub> [mm]	Hmotnost Weight [kg]	
12	81,8	73,6	52	35	20	0,76	16	105,5	97,65	75	35	20	1,49	20	129,7	121,78	80	35	25	1,94	
					22	0,74						22	1,47						28	1,91	
					24	0,72						25	1,44						30	1,89	
					25	0,71						28	1,41						32	1,87	
					28	0,68						30	1,39						35	1,84	
					30	0,66						32	1,37						38	1,81	
												35	1,35						40	1,79	
												38	1,32						42	1,77	
13	87,1	79,60	58	35	20	0,92						40	1,31					45	1,75		
					22	0,90						40	1,31						45	1,75	
					24	0,88	17	111,2	103,67	80	35	22	1,67	21	135,4	127,82	90	40	28	2,48	
					25	0,87						25	1,64						30	2,46	
					28	0,84						28	1,61						32	2,44	
					30	0,82						30	1,59						35	2,42	
					32	0,80						32	1,57						38	2,39	
					35	0,77						35	1,55						40	2,37	
												38	1,52								
												40	1,50								
14	93,8	85,61	64	35	20	1,11						22	1,78								
					22	1,09						25	1,75								
					24	1,07	18	118,0	109,71	80	35	22	1,78								
					25	1,06						25	1,75								
					28	1,03						28	1,72								
					30	1,01						30	1,70								
					32	1,00						32	1,68								
					35	0,97						35	1,65								
												38	1,62								
												40	1,60								
15	99,2	91,63	70	35	20	1,30						25	1,83								
					22	1,28						28	1,80								
					24	1,26	19	123,3	115,75	80	35	25	1,83								
					25	1,25						28	1,80								
					28	1,22						30	1,78								
					30	1,20						32	1,76								
					32	1,18						35	1,74								
					35	1,15						38	1,71								
					38	1,13						40	1,69								
					40	1,11						42	1,67								
												45	1,64								

- Rozměry drážky pro pero (B, T2) a stavěcích šroubů (M) jsou uvedeny na straně 33.
- Řetězová kola mají indukčně kalené zuby, zhotovený otvor včetně drážky pro pero a dva otvory pro stavěcí šrouby v poloze nad drážkou pro pero a pod úhlem 90°, což umožňuje rychlou montáž bez nutnosti dalšího opracování.
- Mimo standardní rozměry upravíme/vyrobíme polotovary v naší obrobně dle Vašich požadavků.

- Keyway dimensions (B, T2) and setscrews dimensions (M) are stated on page 33.
- Sprockets are with induction hardened teeth, finished bore including keyway and 2 setscrew holes in position above keyway and under 90° angle. This sprocket version enables sprocket assembly without any other finishing.
- Upon request we adapt/produce sprockets/plate wheels out of standard dimensions in our workshop.

