

# Řetězová kola přesná s kalenými zuby Finished sprockets with hardened teeth

Řetězové kolo přesné s indukčně kalenými zuby pro válečkový řetěz dle DIN 8187 ISO/R606  
Finished sprockets with hardened teeth for roller chain to DIN 8187 ISO/R606

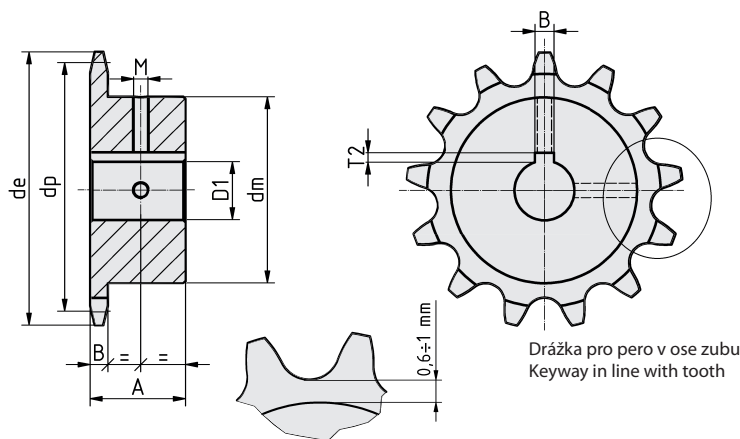

16B-1



Indukčně kalené zuby HRC 45+53  
Induction hardened teeth HRC 45+53

Řetěz • Chain		
Rozteč • Pitch	P	25,4 mm
Vnitřní šířka • Inner width	b <sub>1</sub>	17,02 mm
Průměr válečku • Roller diameter	D	15,88 mm
Řetězové kolo • Sprocket		
Šířka zubů • Sprocket tooth width	B <sub>1</sub>	16,2 mm
Materiál • Raw material	ocel • steel C40/C45 kalena / hardened	

Počet zubů Teeth number Z	d <sub>e</sub> [mm]	d <sub>p</sub> [mm]	d <sub>m</sub> [mm]	A [mm]	D <sub>1</sub> [mm]	Hmotnost Weight [kg]	Počet zubů Teeth number Z	d <sub>e</sub> [mm]	d <sub>p</sub> [mm]	d <sub>m</sub> [mm]	A [mm]	D <sub>1</sub> [mm]	Hmotnost Weight [kg]	Počet zubů Teeth number Z	d <sub>e</sub> [mm]	d <sub>p</sub> [mm]	d <sub>m</sub> [mm]	A [mm]	D <sub>1</sub> [mm]	Hmotnost Weight [kg]
12	109,71	98,14	69	40	25	1,73	16	141,0	130,20	100	45	30	3,48	20	173,2	162,38	100	45	30	4,49
					28	1,71						32	3,46						32	4,47
					32	1,69						38	3,44						35	4,44
					35	1,66						40	3,42						38	4,42
					38	1,63						42	3,40						40	4,40
					40	1,61						45	3,37						42	4,38
												48	3,34						45	4,35
												50	3,32						48	4,32
	117,2	106,14	78	40	25	2,09													50	4,30
					28	2,07								17	149,4	138,22	100	45	30	3,73
					30	2,05						32	3,71	21	181,6	170,43	110	50	30	5,50
					32	2,03						35	3,68						32	5,48
					35	2,00						38	3,66						35	5,45
					38	1,98						40	3,64						38	5,42
					40	1,96						42	3,62						40	5,40
					42	1,94						45	3,59						42	5,38
					45	1,91						48	3,56						45	5,35
												50	3,54						48	5,32
14	125,7	114,15	84	40	25	2,44													50	5,30
					28	2,42								18	157,0	146,28	100	45	30	3,96
					30	2,40						32	3,94	23	198,1	186,1	110	50	30	6,12
					32	2,38						35	3,92						32	6,10
					35	2,35						38	3,90						35	6,07
					38	2,32						40	3,88						38	6,04
					40	2,30						42	3,86						40	6,02
					42	2,28						45	3,83						42	6,00
					45	2,25						48	3,80						45	5,97
					48	2,22						50	3,78						48	5,94
					50	2,20													50	5,92
15	133,3	122,17	92	40	28	2,80	19	165,5	154,33	100	45	30	4,23	25	214,2	202,66	110	50	30	6,78
					30	2,78						32	4,21						32	6,76
					32	2,76						35	4,18						35	6,73
					35	2,73						38	4,15						38	6,70
					38	2,71						40	4,13						40	6,68
					40	2,69						42	4,11						42	6,66
					42	2,67						45	4,08						45	6,63
					45	2,64						48	4,05						48	6,60
					48	2,61						50	4,03						50	6,58
					50	2,59														

- Rozměry drážky pro pero (B, T2) a stavěcích šroubů (M) jsou uvedeny na straně 33.
- Řetězová kola mají indukčně kalené zuby, zhotovený otvor včetně drážky pro pero a dva otvory pro stavěcí šrouby v poloze nad drážkou pro pero a pod úhlem 90°, což umožňuje rychlou montáž bez nutnosti dalšího opracování.
- Mimo standardní rozměry upravíme/vyrobíme polotovary v naší obrobně dle Vašich požadavků.
- Keyway dimensions (B, T2) and setscrews dimensions (M) are stated on page 33.
- Sprockets are with induction hardened teeth, finished bore including keyway and 2 setscrew holes in position above keyway and under 90° angle. This sprocket version enables sprocket assembly without any other finishing.
- Upon request we adapt/produce sprockets/plate wheels out of standard dimensions in our workshop.